

RAD61L

Universal Battery Pack 61kWh

POWER UNDER THE DECK

Under deck battery system with advanced thermal management and sustained power delivery to get your electric boat moving fast.

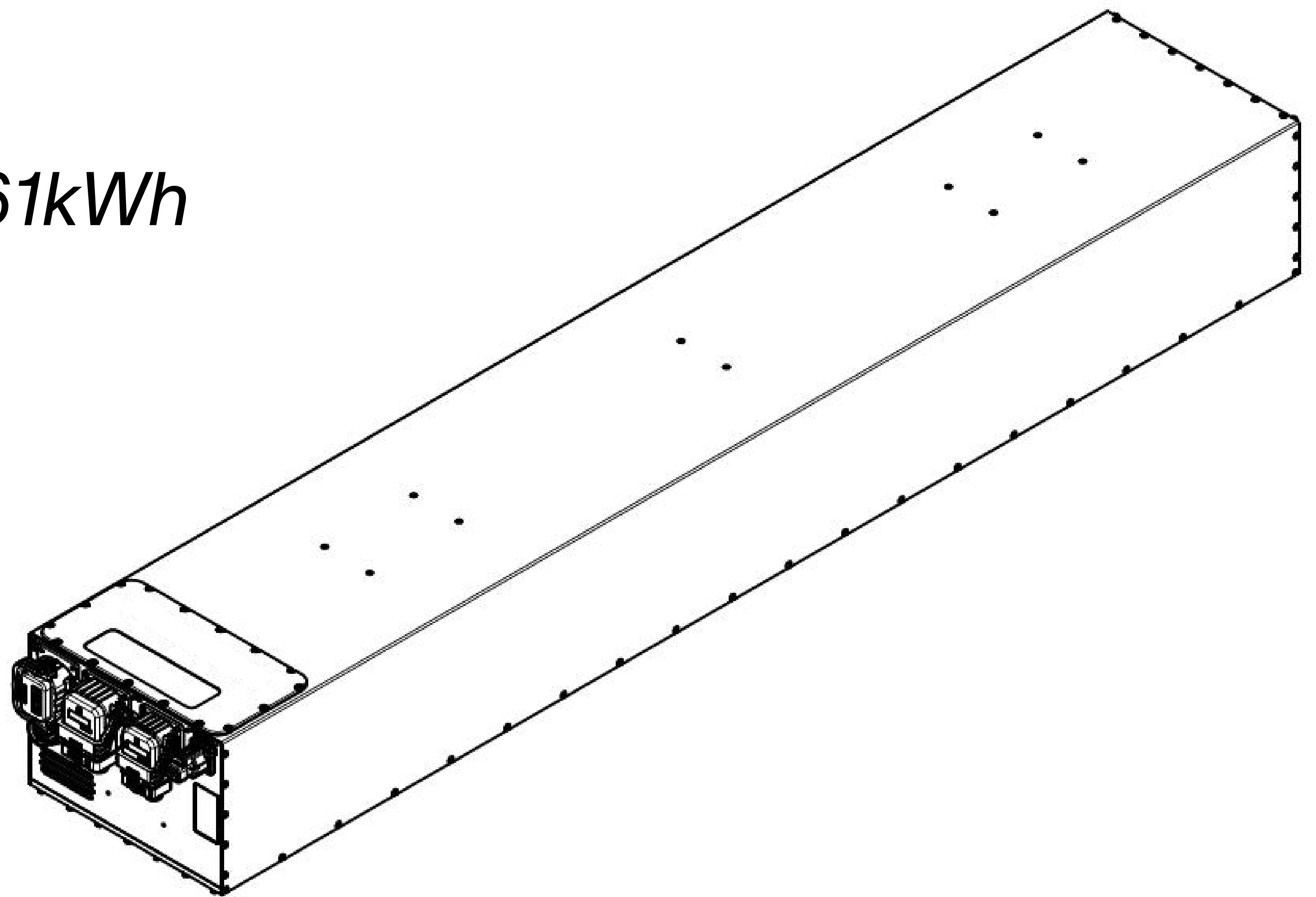

CAPACITY	NOMINAL VOLTAGE	PEAK DISCHARGE	CCS CHARGE RATE	PROTECTION	WEIGHT
61kWh	390v	280kW	70kW	IP67	358kg

SOFTWARE LIMITED

Fits in (almost) any boat

Compact, high density battery pack to fit under or on the deck. Selection of mounting points along the bottom and on the top.

Fast Input, Big Output

61kWh gives up to 80nm of range with recharge in under an hour via CCS DC charging. Built in contactor control, pre-charge, battery management and safety systems. 1 x 25A auxiliary outputs for AC charger and other systems. Bolt or weld in, add cooling and 12v ignition.

Just Add Motor

Nominal 390 volts and 280kW peak output mean sustained energy for the most popular and powerful RAD propulsion systems.

SPECIFICATIONS

ELECTRICAL	Capacity	61.2 kWh	MECHANICAL	Main Dimensions	372W x 2147D x 268H mm	
	Nominal Voltage	390 volts		Weight	358 kg	
	Max Voltage	453 volts		Enclosure Materials	Stainless Steel and Aluminum	
	Max Charge Voltage	442 volts		ENVIRONMENTAL	Thermal Management	Aluminium Cold Plates
	Min Voltage	345 volts			Coolant Requirements	50% Glycol / 50% Water
	Min Voltage Under Load	302 volts	Coolant Pressure/ Flow MAX		18 psi - 23 Ltr/min	
	CCS Charging Rate	70 kW	Stationary Temp		-20°C to 65°C	
	Main Fuse	1 x 630 amp	Operational Temp		-10°C to 55°C	
	Auxiliary HV Outputs	2 x 25 amp	OTHER	Battery Chemistry	NCM-156FM (1p12s 156ah)	
	Continuous Discharge	55 kW		Battery Cell Configuration	108 in Series	
Discharge 3 Seconds	280 kW	Data Connection		Deutsch HDP24-24-35PE		
Discharge 10 Seconds	180 kW	Regulation		EU R100.1 Compliant AU VSB14 Compliant		

KEY COMPONENTS

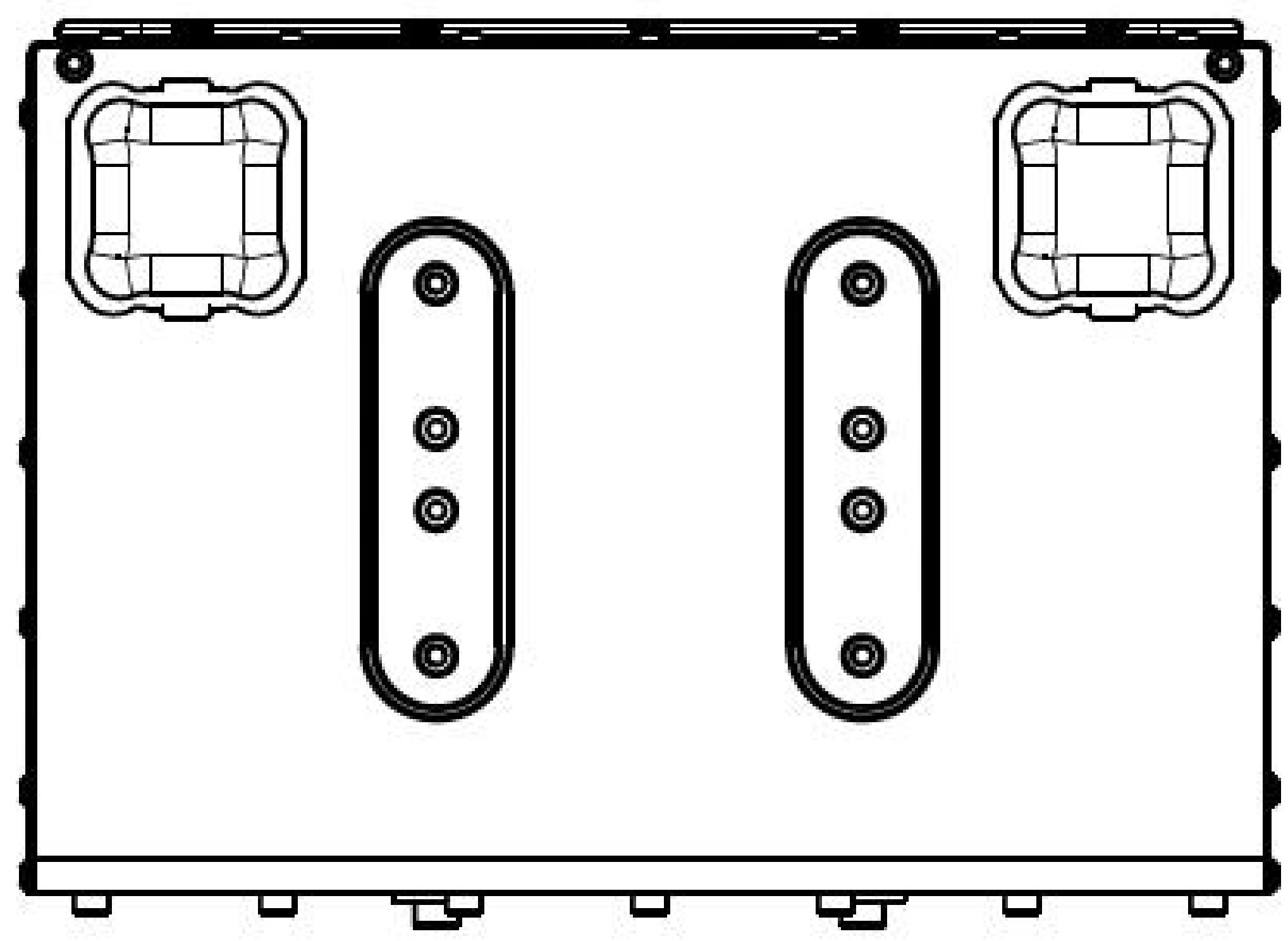
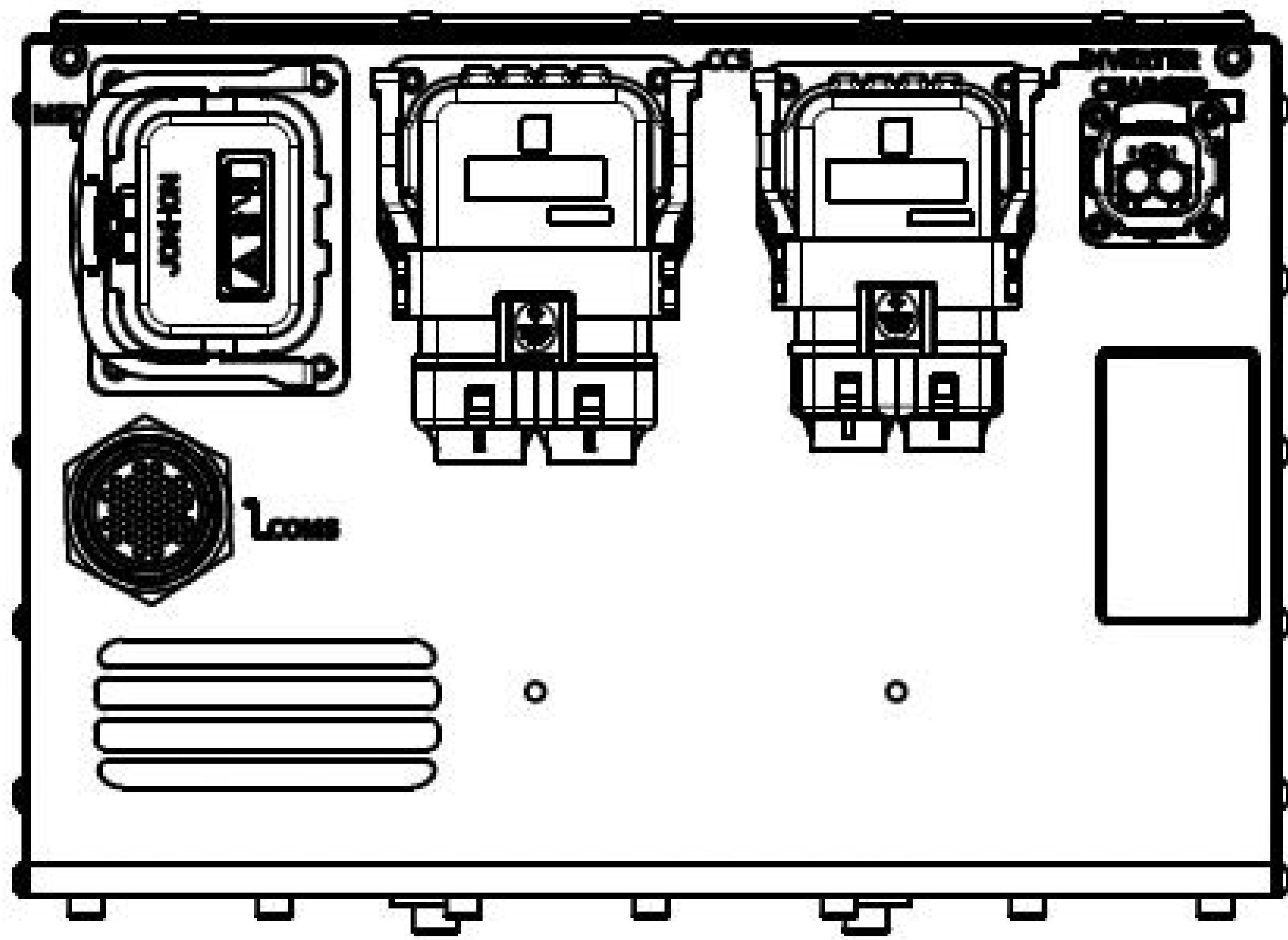

HIGH VOLTAGE CONNECTIONS POLARITY

LOW VOLTAGE CONNECTIONS

CCS HV CONNECTOR

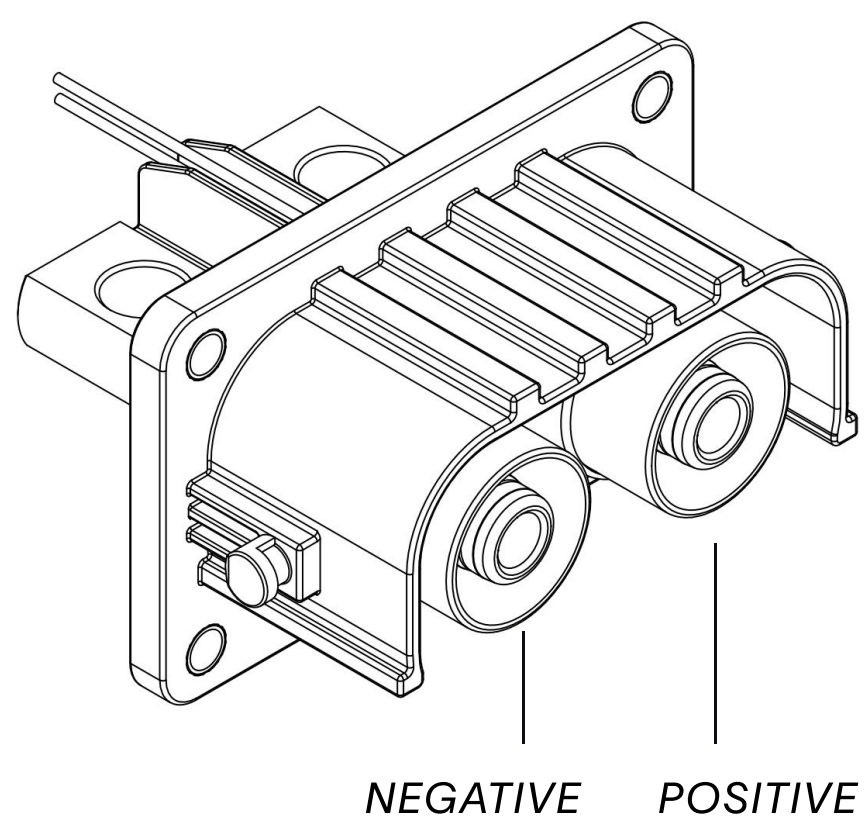

DRIVE UNIT HV CONNECTOR

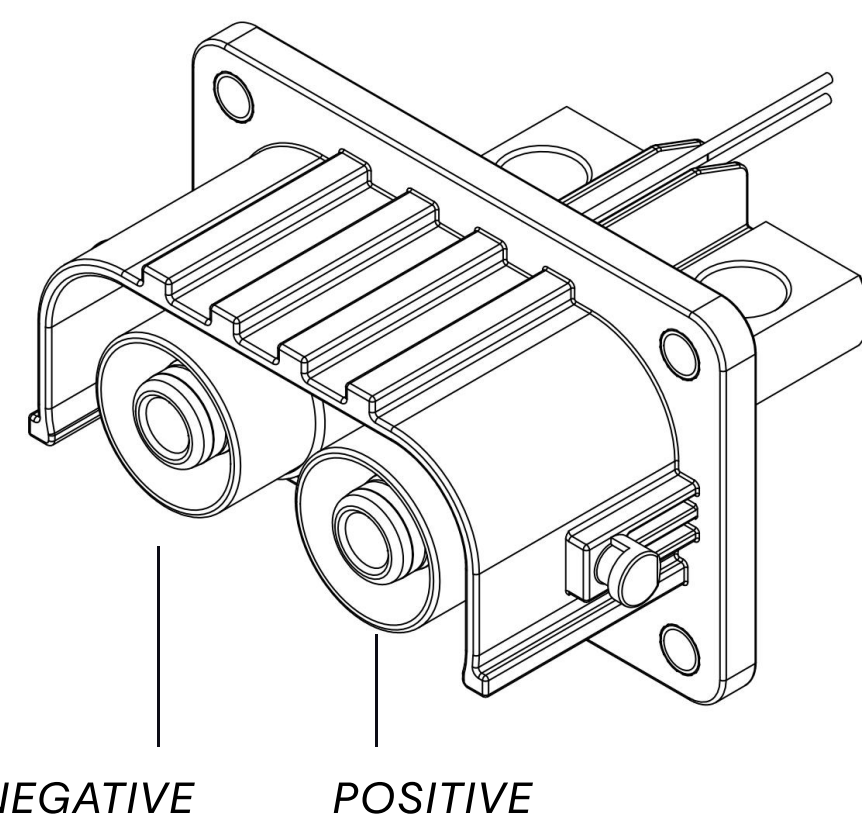

DEUTSCH DT+DTM 35 PIN PLUG
HDP24-24-35PE

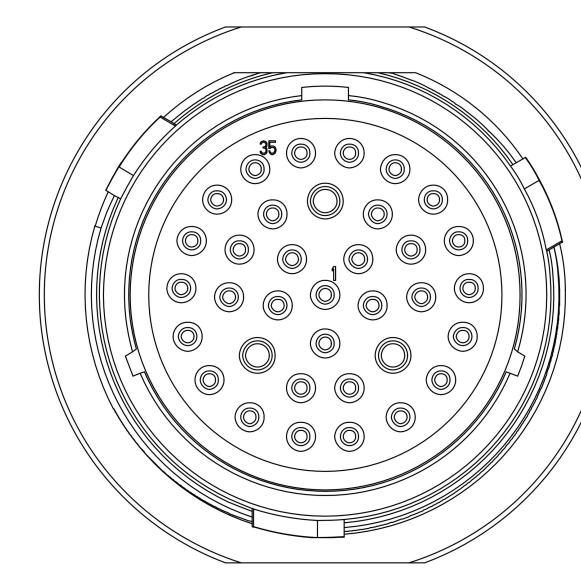

1 X 25 AMP HV CONNECTOR

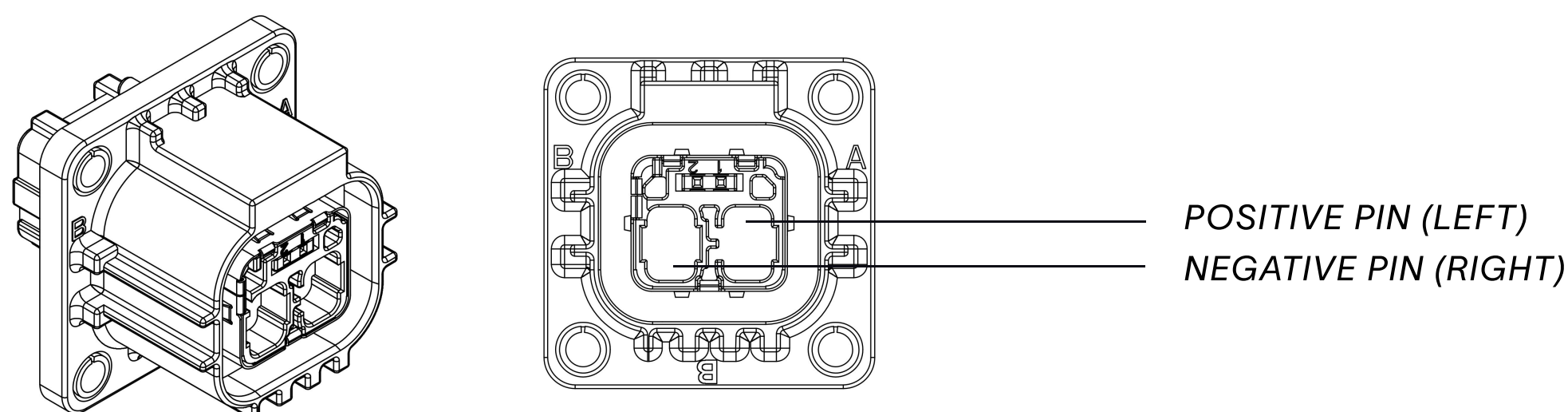

LOCK MOTOR PLUG

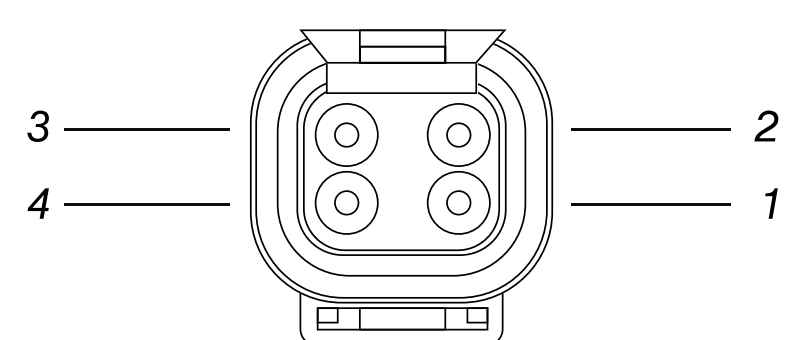

PIN	DESCRIPTION	NAME	COLOUR
1	Lock motor out -	FB_OUT0	Red
2	Lock motor out +	FB_OUT1	White
3	Lock motor Input - Inverted	LOCKMOTOR_SW	Yellow
4	Constant 12V	12V_CONSTANT	Blue

CHARGE STATUS/LOCK BUTTON PLUG

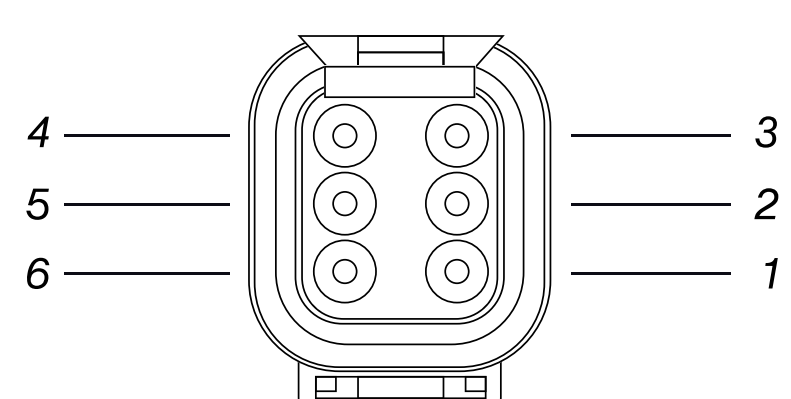

PIN	DESCRIPTION	NAME	COLOUR
1	Charge Stop Switch	STOP_SW	Yellow
2	Constant 12V	12V_CONST	White
3	Ground	GROUND	Black
4	Charge Status LED - Red	LED0	Red
5	Charge Status LED - GREEN	LED1	Green
6	Charge Status LED - Blue	LED2	Blue

PIN	DESCRIPTION	NAME	FUNCTION
1	Switched 12V - Charge	CHARGE	Voltage output
2	BMS CAN 1 & Contactor Control	CAN1_H	Comms
3	BMS CAN 1 & Contactor Control	CAN1_L	Comms
4	BMS CAN 2	CAN2_L	Comms
5	BMS CAN 2	CAN2_H	Comms
6	BMS Secondary Control	REMOTE +	Comms
7	Switched 12V - Ignition	IGN	Voltage Input
8	BMS Secondary Control	REMOTE -	Comms
9	BMS Secondary Control	REMOTE_SHIELD	Comms
10	Charge Status LED - Green	LED1	Signal Output
11	Ground	GND	Voltage Input
12	Contactor Control 12V supply	CONT_CONT_SUPPLY	Voltage Input
13	Charge Status LED - Red	LED0	Signal Output
14	Constant 12V	12V CONST	Voltage Input
15	BMS Discharge Enable	DISCHARGE_EN	Signal Output
16	BMS Charge Enable	CHARGE_EN	Signal Output
17	Lock motor out -	FB_OUT0	Signal Output
18	Lock motor out +	FB_OUT1	Signal Output
19	Charge Port Temp 0 +	PTC0+	Signal Input
20	BMS MPO3 - Fan enable	FAN_EN/MPO3	Signal Output
21	Charge Port Temp 0 -	PTC0-	Signal Input
22	BMS MPI1 - J1772 Pilot	CP	Signal Input
23	Charge Port Temp 1 +	PTC1+	Signal Input
24	Charge Port Temp 1 -	PTC1-	Signal Input
25	Charge Status LED - Blue	LED2	Signal Output
26	Lockmotor Input	POS_FB	Signal Input
27	Lockmotor Input - Inverted	LOCKMOTOR_SW	Signal Input
28	BMS MPI2 - J1772 Proximity	PP	Signal Input
29	Charge Stop Switch	STOP_SW	Signal Input
30	High Voltage Interlock	HVIL	Signal I/O
31	High Voltage Interlock	HVIL	Signal I/O
32	High Voltage Present	HV_PRESENT	Signal Output
33	-	-	-
34	-	-	-
35	-	-	-

KEY COMPONENTS

